



# ENCARDIO RITE

ONE STOP MONITORING SOLUTIONS | HYDROLOGY | GEOTECHNICAL | STRUCTURAL | GEODETIC  
Over 50 years of excellence through ingenuity

---

**USERS' MANUAL**

---

## MULTIPOINT BOREHOLE EXTENSOMETER (MECHANICAL)

MODEL EDS-63UD



Doc # WI 6002.77 R01 | Jun 2019

---

**ENCARDIO-RITE ELECTRONICS PVT. LTD.**

A-7, Industrial Estate, Talkatora Road Lucknow, UP - 226011, India | P: +91 522 2661039-42 | Email: [geotech@encardio.com](mailto:geotech@encardio.com) | [www.encardio.com](http://www.encardio.com)

International: UAE | Qatar | Bahrain | Bhutan | Europe | USA

India: Lucknow | Delhi | Kolkata | Mumbai | Chennai | Bangalore | Hyderabad | J&K

## Contents

<b>1</b>	<b>INTRODUCTION</b>	<b>1</b>
1.1	Applications	1
1.2	Measurement method	1
1.3	Anchors	1
1.4	Conventions used in this manual	2
1.5	How to use this manual	2
<b>2</b>	<b>BOREHOLE EXTENSOMETER</b>	<b>3</b>
2.1	Introduction	3
2.2	System description	4
2.2.1	Reference head assembly	4
2.2.2	Connecting rod assembly	4
2.2.3	Anchor	5
2.3	Tools & accessories required for installation	6
<b>3</b>	<b>INSTALLATION</b>	<b>7</b>
3.1	Installation with Fibreglass rod assembly	7
3.1.1	Site preparation before installation	7
3.1.2	Procedure	7
3.2	Installation of borehole extensometer with stainless steel connecting rod assembly	10
3.2.1	Procedure for installing the stainless steel connecting rods	10

## 1 INTRODUCTION

---

Encardio-rite borehole extensometer is a precision instrument designed to help civil engineers and geologists in measurement of deformation of rock mass and adjacent or surrounding soil. Together with anchor bolt load cell and tape extensometer, it is an essential piece of equipment for investigation and monitoring of foundations, slopes & embankments and for studying the behaviour of rock around underground cavities, tunnels and mines.

Model EDS-63U/D borehole extensometer can be used for upward or downward sloping hole using fibreglass connecting rods or stainless steel extension rods.

In model EDS-63U/D system offered by Encardio-rite, up to three extensometers can be installed in a borehole of  $\phi$  76 mm with diameter at the mouth of borehole increased to 90 mm up to a depth of 200 mm. Up to six extensometers can be installed in a borehole of  $\phi$  102 mm with diameter at the mouth of borehole increased to 125 mm to a depth of 225 mm.

**NOTE:** This instruction manual gives procedure for mounting up to 6 extensometers in a downward slanting hole. For mounting in vertically upward to horizontal borehole modify procedure suitably.

For borehole extensometers installed in deep boreholes, grouting in stages may be necessary. In such a case consult factory at Lucknow.

### 1.1 Applications

- To determine how roof or wall of mine, underground cavity or tunnel behaves during excavation.
- To study effectiveness of roof/wall support system of a mine, underground cavity or tunnel.
- To predict potential roof or wall falls before they actually occur. Roof or wall falls in underground cavities are almost invariably preceded by measurable sags as the strata opens up and the movement usually occurs at an increasing rate as fall conditions are approached. Unsuspected roof and wall falls may result in serious accidents and may require costly patch-up and repair operations.
- To measure and monitor movements in slopes and foundations due to excavation of underground cavities or due to construction of heavy structures like concrete, rock fill, masonry or earth dams over the foundation.

### 1.2 Measurement method

Displacement is measured by using a micrometer depth gage.

### 1.3 Anchors

Following type of anchors are available from Encardio-rite:

- Encardio-rite groutable anchors  $\phi$  20 mm x 500 mm long usually used for hard rocks. These are lowered down or pushed in borehole along with connecting rod of appropriate length and fixed in position by cement grout. The connecting rod is protected from cement grout by enclosing in nylon tubing, thus allowing for its free movement. Groutable anchors may be installed in vertical boreholes or holes inclined upwards. Installation of groutable anchors in holes inclined upwards needs special precautions to retain grout and prevent it from flowing out of the borehole.
- Encardio-rite packer anchors usually used for soft rocks and soil. These are lowered down or pushed in borehole along with connecting rod of appropriate length and fixed in position by pumping cement grout into the packer for taking a firm grip with the surroundings.

**NOTE:** Encardio-rite uses convention that depth of anchor is calculated as distance from the mouth of hole to near end of anchor.

#### 1.4 Conventions used in this manual

**WARNING!** Warning messages calls attention to a procedure or practice, that if not properly followed could possibly cause personal injury.

**CAUTION:** Caution messages calls attention to a procedure or practice, that if not properly followed may result in loss of data or damage to equipment.

**NOTE:** Note contains important information and is set off from regular text to draw the users' attention.

#### 1.5 How to use this manual

The users' manual is intended to provide sufficient information for making optimum use of borehole extensometers in different applications.

To make the manual more useful we invite valuable comments and suggestions regarding any additions or enhancements. We also request to please let us know of any errors that are found while going through this manual.

**NOTE:** The installation personnel must have a background of good installation practices and knowledge of fundamentals of geotechnics. Novices may find it very difficult to carry on the installation work. The intricacies involved in installation are such that even if a single essential but apparently minor requirement is ignored or overlooked, the most reliable of instruments will be rendered useless.

A lot of effort has gone in preparing this instruction manual. However the best of instruction manuals cannot provide for each and every condition in the field, which may affect performance of the instrument. Also, blindly following the instruction manual will not guarantee success. Depending upon field conditions, installation personnel will have to consciously depart from the written text and use their knowledge and common sense to find the solution to a particular problem.

The manual is divided into a number of sections, each section containing a specific type of information. The list given below tells you where to look for in this manual if you need some specific information. It is however recommended that you read the manual from beginning to end to get a thorough grasp of the subject. You will find a lot of unexpected information in sections you feel you may skip.

*For description of borehole extensometer manufactured by Encardio-rite: See § 2.1 "Introduction" and § 2.2 "General Description".*

*For installation of multi position borehole extensometers: See § 3 "Installation".*

*For tools & accessories required for installation: See § 3.3 "Tools & accessories required for installation".*

## 2 BOREHOLE EXTENSOMETER

### 2.1 Introduction

Borehole extensometer measures displacement taking place in a borehole with reference to time. Extensometer helps to accurately measure change in distance between various anchors (1) with respect to reference plate (6.9) and monitor GL their relative displacement with passage of time. It is usually assumed that the deepest anchor is in stable ground and so any change in anchor spacing is interpreted as sag of roof bed, movement of side wall or slope, settlement of foundation etc.

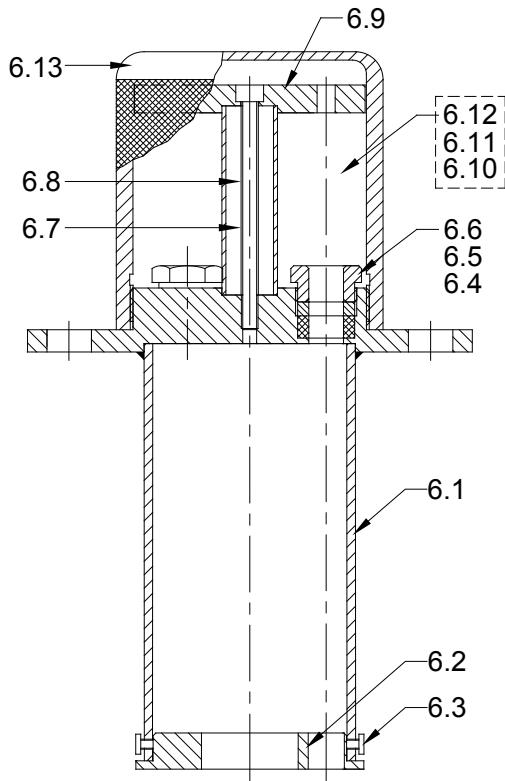

Figure 2-1 – Reference Head Assembly

Sl. #	Description
6.1	Flanged housing
6.2	Guide plate
6.3	Ch. Head screw, M6 x 8 mm.
6.4	Rubber bush
6.5	Washer
6.6	Hollow bolt
6.7	Central spacer
6.8	Allen head bolt, M6x 80
6.9	Reference plate
6.10	Setting spacer
6.11	C'sk screw M6 x 50
6.12	Reference button
6.13	Cover

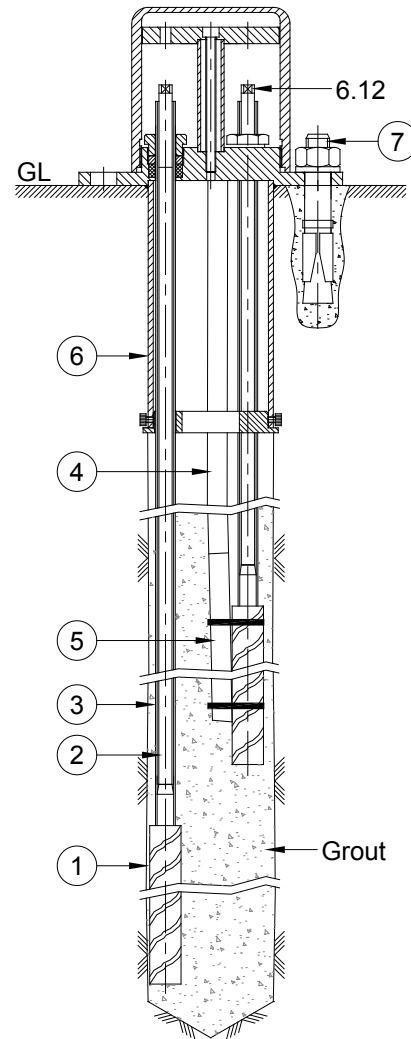

Figure 2-2 – Borehole Extensometer Assembly

Sl. #	Description
1	Anchor
2	Connecting rod assembly of required length
3	Protective sleeve
4	Grout pipe
5	Air vent tube
6	Reference head assembly
7	Fastener

## System description

EDS-63U/D essentially is a system in which up to six anchors can be mounted in a borehole and their relative displacement monitored with time with respect to a reference plate.

At locations where access to mouth of borehole is easily available, mechanical measurement of displacement by EDS-63U/D is economical and reliable. Displacement reading is taken by a micrometer depth gage by measuring depth of reference button at near end of connecting rod from a reference plate.

Borehole extensometer basically comprises of three major components:

- Reference head assembly
- Fibreglass assembly
- Anchor

### 2.2.1 Reference head assembly

Refer to figure 2.1 and part list below it for details. Reference head assembly for up to 6 extensometers is installed in a borehole of  $\phi$  102 mm. The diameter at the mouth of borehole is increased to 125 mm up to a depth of 225 mm. The flange has four 18 mm diameter mounting holes at a PCD of 158 mm.

If less than six points are required other points are plugged with the help of standard rubber plug, steel washer and hollow hex bolts.

### 2.2.2 Connecting rod assembly

#### 2.2.2.1 Fibreglass rod assembly

It comprises of a fibreglass rod of specified length protected inside an outer continuous nylon tube. The rod has end two connectors. One end connector has a male thread and fits into the anchor. The other end connector with a female thread is for the reference button. The anchor end of nylon tube is firmly sealed with the anchor to prevent any grout from leaking in. The other end of the nylon tube is firmly sealed in the reference head assembly (refer 6.4 – 6.6 in figure 2.1). Proper sealing in the reference head assembly is especially necessary for upwards to horizontally slanting holes for preventing any grout for leaking into the reference head assembly during grouting.

The outer nylon tube allows free movement to fibreglass rod and reference button even after borehole is grouted.



Figure 2-3 – Fibreglass rod assembly

**NOTE:** Fibreglass rods are generally more suitable for vertically upward holes as compared to downward holes. This is because in vertically upward holes the rod is in tension; whereas in downward holes it is in compression, resulting in sagging or buckling. Longer the extensometer, greater may be the sagging or buckling.

Shorter the extensometer, better is accuracy of measurement of relative displacement between anchors. In deeper boreholes, use of stainless steel connecting rods is recommended, as they are more rigid.

Design Engineer should carefully consider what type of connecting rod to use taking into consideration field conditions and accuracy of measurement required. Actual performance of

rods is determined by site conditions and it is recommended to conduct some field tests to arrive at a proper conclusion.

### **2.2.2.2 Stainless steel AISI 410 connecting rod assembly**

Stainless steel AISI 410 connecting rods of 8 mm diameter are available in standard lengths of 1m, 2 m and 3 m with a M6 x 12 mm male thread at one end and a M6 x 15 mm female thread at other end. These are connected together at site for positioning anchor at the correct depth from mouth of borehole. Thread sealant Loctite 577 or equivalent is used between threads to firmly grip connecting rods to each other.

To give an example, in case depth of a particular anchor from the mouth is 14 m, use four connecting rods of 3 m length and one of 2 m length. Similarly, in case depth of anchor from the mouth is 25 m, use eight connecting rods of 3 m length and one connecting rod of 1 m.

On the near end of assembled connecting rods a standard 14 cm spacer with male thread on one side and female on the other side is always provided. The reference button (6.12) is threaded into the female end of this spacer. The male thread of bottom most connecting rod (most distant from the mouth of the borehole) fits into the anchor (1).

PVC tubing 14 mm od x 10 mm id in 3 m length is provided for enclosing connecting rods at time of assembly. One end of these tubes is swaged to form a male extender such that male and female ends of successive PVC tubes can be conveniently assembled to each other using any PVC jointing compound in-between. After jointing, the joint should always be checked by pulling and then wrapped with PVC tape to make it leak proof. The outer PVC tubing allows free movement to connecting rods and reference button even after borehole is grouted.

The furthest PVC tubing from mouth of borehole is firmly sealed to the anchor to prevent any grout from leaking in. This 3 m long PVC tubing is cut by 50 mm from the plain end to make it convenient for successive connecting rods and PVC tubings to be connected together.

The near end of the PVC tubing is firmly sealed in flanged housing (6.1) with help of rubber bush (6.4), washer (6.5) and hollow bolt (6.6). The PVC tube should be cut such that when sealed in flanged housing, its face extends around 20 mm beyond rubber bush (6.4). Proper sealing in reference head assembly is especially necessary for upwards to horizontally slanting holes for preventing any grout for leaking into reference head assembly during grouting.

### **2.2.3 *Anchor***

#### **2.2.3.1 Groutable anchor**

Reinforced bar groutable anchor of diameter 20 mm x 500 mm long is typically used in rock.

In case groutable anchor is installed in deep borehole, grouting in stages may be necessary and this may require some modification in the design. In such a case consult factory at Lucknow.



**Figure 2-4 – Groutable anchor**

### 2.2.3.2 Packer anchor

Packer anchor with geotextile bladder inflated with grout is generally used in fractured rock or soil.

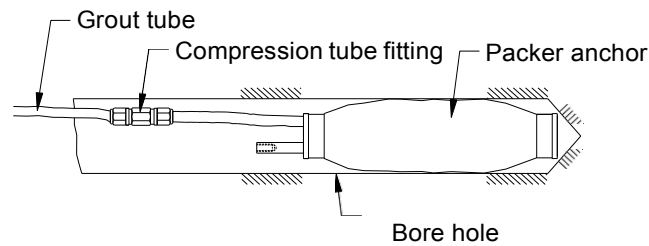

**Figure 2-5 – Packer anchor**

**NOTE:** Encardio-rite uses the convention that depth of anchor is calculated as distance from mouth of hole to near end of anchor.

## 2.3 Tools & accessories required for installation

The following tools and accessories are required for proper installation of the multi position borehole extensometer:

- Loctite 290 and Loctite 415 or equivalent
- Acetone (commercial)
- Spanner size 22
- Screw driver
- Allen key
- Hacksaw with 150 mm blade
- Pliers 160 mm
- 150 mm flat file
- Tube cutter
- M6 threading tap with handle
- M6 threading die with handle
- Wire brush
- Cloth for cleaning (lintless)
- Insulation tape
- Micrometer depth gage 100 mm range



### 3 INSTALLATION

#### 3.1 Installation with Fibreglass rod assembly

**NOTE:** Procedure described below is for installing borehole extensometer upto 6 points in a downward sloping hole using groutable anchors. For installation in an upward to horizontally sloping borehole, or for using packer anchors, modify procedure suitably.

##### 3.1.1 Site preparation before installation

1. Drill hole of 102 mm diameter to a depth of 0.5 m ~ 1 m more than length of deepest anchor.

**NOTE:** In case borehole extensometer is to be mounted horizontally and design permits, it is desirable to provide a downward slope of 5° or more to the borehole. This facilitates grouting of anchors as grout can easily flow in.

2. At the mouth of hole, increase diameter of drilled hole to 125 mm up to a depth of 225 mm for wrapping outside of housing with rags or jute cloth strips soaked in cement.
3. Insert reference head assembly centralized in the 125 mm borehole. Taking holes on flange as reference, drill four holes 18 mm diameter x 150 mm deep for fastening flange to borehole. Remove reference head assembly from borehole.
4. Wash hole clean upto bottom by pumping in fresh water.

##### 3.1.2 Procedure

1. If less than six points are required, plug other points on reference head assembly with help of standard rubber plug, steel washer and hollow hex bolts (6.6).
2. Apply Loctite 415 or equivalent on machined portion of groutable anchor. Screw male end connector of longest fibre glass rod assembly to groutable anchor using Loctite 290 or equivalent as a thread sealant. In the process, the nylon tubing will also get firmly gripped to groutable anchor.
3. Refer to figure 2-1. Remove cover (6.13) from flanged housing (6.1) and place latter flat on the ground. Loosen all hollow bolts (6.6) slightly.
4. Insert groutable anchor into borehole till other end of fiberglass rod is around 1 m - 1.5 m outside face of borehole. Trim nylon sleeve such that female connector on fiberglass rod is exposed by around 10 mm.

**WARNING!** The fibreglass rod is supplied in coil form using cable ties. It is very stiff material and must be carefully handled when unwinding as the end may snap back and cause personal injury.

5. Guide end of fiberglass rod through corresponding hole in guide plate (6.2) to emerge through hole marked '1' on flanged housing top (6.1). Fiberglass rod will have to be bent to achieve this. Locate setting spacer (6.10) between reference plate (6.9) and female connector end of fiberglass rod. Insert screw (6.11) through reference plate hole and

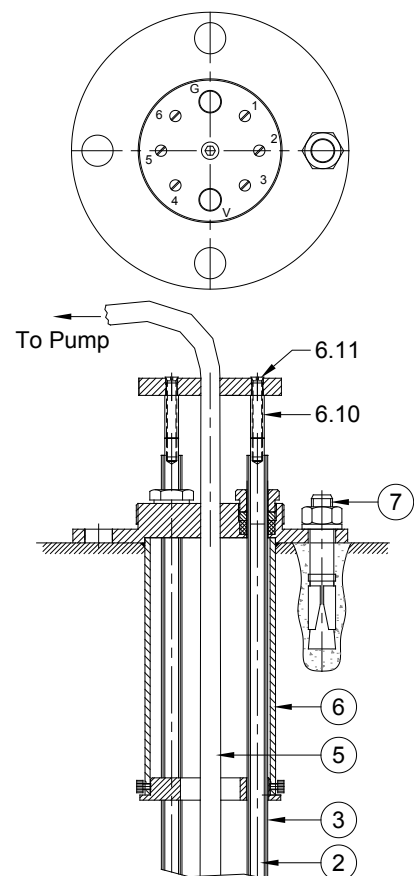

**Figure 3.2** – Installation in borehole

screw through setting spacer into female connector end. When tightened, reference button will be at a depth of around 25 mm from top of reference plate. In case this distance is to be maintained different, use different length setting spacer (6.10).

6. In case hole in reference plate is not aligned with hole marked '1' in flanged housing, loosen Allen head bolt (6.8) and retighten after aligning



**NOTE:** On side wall and roof where extension is generally expected, it may be desirable to use a 5-10 mm setting spacer (6.10). Similarly, in a vertically down borehole where settlement is generally expected, it may be desirable to use a setting spacer of 40-45 mm.

7. Tighten hollow bolt (6.6) with spanner size 22 mm to firmly grip nylon tube but not to squeeze or hinder free movement of female end connector inside the nylon tube.

**NOTE:** In upward to horizontally sloping borehole, be particularly careful in tightening the hollow bolts (6.6) properly as grout may leak through into the reference head assembly during the grouting process.

**NOTE:** Always assemble and mount deepest anchor first. This is a good convention to follow to avoid any confusion at a later date in identification of anchors. Holes on top of flanged housing are marked clockwise with identification numbers 1, 2, 3, V, 4, 5, 6 and G respectively.

As an Encardio-rite convention, serial number '1' always corresponds to deepest anchor, serial number '2' corresponds to second deepest anchor and so on. Also as an Encardio-rite convention, looking into hole, serial numbers are always in a clockwise direction.

As an additional precaution, make a note in a diary of orientation of serial number '1' with geographical North.

8. Install all fiberglass connecting rods in descending order of their length as per procedure described in § 3.2.2 - 3.2.5.

**NOTE:** Take care that extensometer assembly does not drop into borehole accidentally. It is advisable to secure it properly by attaching a safety rope to the anchor.

9. Install grout tube in same manner as described in § 3.2.2 - 3.2.5. Generally, lower end of grout tube is kept at a level higher than the anchor closest to the borehole face. While inserting last anchor in borehole, lowest end of grout tube is tied with a cable tie to fiberglass connecting rod. To determine length of grout tube ensure that around 1.5 m is outside the flanged housing (6.1) for ease in attaching it to grout pump.

**NOTE:** In upward to horizontally sloping borehole, grout tube should be about 1.5 m longer than depth of deepest anchor and taped around 300 mm below far end of anchor. Tape grout tube every 2 m with an insulation tape to the nylon tube to prevent it from swinging loose.

10. Install around 2 m long air vent tube in same manner as described in § 3.2.2 - 3.2.5 keeping in view that grout should cover the anchor closest to the mouth or be around 1 m from the face of the borehole whichever distance is less. Lower end of air vent tube should always be at a higher level than lower end of grout tube.

**NOTE:** In upward to horizontally sloping borehole, air vent tube should be about 0.5 m longer than depth of deepest anchor and taped around 50 mm above far end of anchor. Tape air vent tube every 2 m with an insulation tape to the nylon tube to prevent it from swinging loose. Top end of air vent tube should be at a level higher than the deepest anchor.

**CAUTION:** In upward to horizontally sloping borehole, care should be taken that air vent tube is taped around 50 mm beyond rear of longest anchor and should not get detached. This is very necessary for the grout to fill in up to end of longest anchor.

11. Wrap rags or jute cloth strips soaked in quick setting cement water mix outside flanged housing (6.1) to build up approximately 5 mm thick layer. Lift and insert housing in borehole using a to and fro screwing motion sealing the annular space between housing and borehole. Fix fasteners ('7' in figure 2.2) in holes drilled earlier for securing flanged housing. Given enough time to let flanged housing set in borehole.

12. Connect grout pipe to grouting machine and pump grout till the entire cavity is filled up to tip of air vent pipe. Let grout set in for 8-12 hours.

**NOTE:** Check Engineer for cement water proportion to be used in grout. Composition of grout to be used depends upon site conditions. In case of hard rock, 50 kg of cement with 30 kg of water has been successfully used at some project sites.

**NOTE:** Grout should cover the anchor closest to the mouth or be around 1 m from the face of the borehole whichever distance is less.

**CAUTION:** Please ensure that no grout overflows into the flanged housing. In case it overflows, it may get into the protective nylon tubing and may also jam the setting rods.

13. Again pump grout into the system after the 8-12 hours setting period is over to ensure that all the anchors are properly grouted. During setting, the heavier grout has a tendency to settle down leaving water at the top with a possibility that anchors near the face of the borehole are not properly grouted. Rule this possibility out by pumping grout again and ensuring that any such water at the top is pumped out through the air vent tube and replaced by grout.

**CAUTION:** To get correct displacement readings, ensure that all anchors are properly grouted. This problem may be particularly faced in case of near anchors in downward boreholes and rear anchors in upward holes where with the cement in grout settling down, there may only be water around the anchors.

14. Remove screws (6.11) and setting spacers (6.10). Cut the grout and vent tubes from the root and remove them. Clean reference head assembly properly.

15. Fix reference buttons to top of fibreglass rods.

16. Take initial readings with help of depth micrometer. It is recommended to note date, time and temperature while taking the initial reading. Subsequent readings will determine relative displacement between anchors.

### 3.2 Installation of borehole extensometer with stainless steel connecting rod assembly

In case stainless connecting rods are being used in place of fibreglass connecting rods, following procedure needs to be followed. Other installation procedure will remain same as explained in section 3.1 and in figure 2.1, Figure 2.2 and Figure 3.2.

#### 3.2.1 Procedure for installing the stainless steel connecting rods

- Sort out the components required for completing individual borehole extensometer assemblies in individual groups. Connecting rods are available in 1, 2 and 3 m lengths with a M6 x 12 mm male thread at one end and a M6 x 15 mm female thread at the other end.

For example, in case an extensometer is 16 m long, it can be assembled with five connecting rods of 3 m and one connecting rod of 1 m length threaded to an anchor.

**NOTE:** For borehole extensometer assembly requiring depth in fraction of a meter, a special fractional length connecting rod is provided. Refer to the packing list for details.

**NOTE:** Encardio-rite uses the convention that the depth of anchor is calculated as distance from mouth of the hole to near end of anchor.

- Install extensometer assembly with deepest anchor first. Extensometers should always be assembled with the deepest anchor first to the shortest anchor last. Thread the longest connecting rod of the deepest extensometer to the anchor. Assume for this example that it is 3 m long. Use Loctite 577 as a thread sealant.

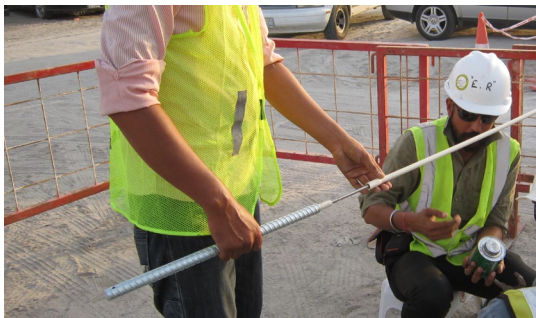

Installation pictures from site

**NOTE:** Always use Loctite 577 as a thread sealant for securing the connecting rod to the anchor and between connecting rod threads.

- Cut a 3 m long PVC rigid pipe (3) by 150 mm from the plain end. The other end has a socket to connect to the next PVC pipe. Insert this 2.85 m long PVC pipe over the connecting rod and fix it to the end of the anchor with Loctite 577. In case the PVC pipe is loose over the anchor end, use a thick coat of Mahendra's M-Seal compound for a good joint. The PVC pipe should make a firm joint with the anchor end to prevent any grout from seeping in.

**NOTE:** The joint between the anchor and the PVC pipe should be leak proof to prevent any grout from seeping in.

- Take a flexible PVC grout tube of 30 kg/cm<sup>2</sup> burst pressure rating (12.5 mm bore x 2 mm wall thickness) around 2 m longer than the length of the deepest anchor. Lightly tape it or secure it by rubber bands to the anchor such that it is around 50 mm beyond the far end of the anchor. The tubing is gradually withdrawn as the grout is filled into the hole and therefore should loosely grip the anchor.

**NOTE:** The PVC grout tubing is gradually withdrawn as the grout is filled into the hole and therefore should loosely grip the anchor.

- Carefully push the anchor, connecting rod, PVC pipe assembly and the grout pipe inside the borehole.
- Thread another connecting rod of required length using Loctite 577 as a thread sealant. Continue the procedure till all the connecting rods are assembled taking care that they are properly enclosed with PVC protective rigid pipe (3). The PVC to PVC pipe sealing may be done with Loctite 577 or any PVC jointing compound. The latter takes less time. While assembling the last connecting rod take care that the overall length of the PVC tubing is 150 mm shorter than the length of the connecting rods.
- Slide the rubber boot over the connecting rod and fix it over the PVC tubing face with Loctite 577. Keep the extensometer end around 300 mm outside the face of housing (6).

**NOTE:** Take care that the extensometer assembly does not drop into borehole accidentally. Secure it properly by attaching a safety rope to the anchor or using suitable safety clamps.

Safety clamps are available from Encardio-rite. They have a groove that fits into the spanner slot on the connecting rod.

- Assemble the next longest anchor assembly in the same manner as described under serial number 3-7. Follow the same sequence for installing the other anchor assemblies also.
- Use a strip of paper and cello tape to mark the connecting rods with numbers '1', '2', '3' etc. marking the deepest extensometer anchor assembly as '1'.

**NOTE:** A grout tube with one end fixed to the deepest anchor is usually adequate for a vertical down hole. Tubing is drawn up from borehole as grout is pumped in. Sometimes a second shorter grout tube is taped to an anchor about halfway down the length of the extensometer. This tube can be used if difficulties may arise with the longer tube.

The hole in the reference plate (Refer Figure 2.1) (6.9) is 13 mm diameter. If two grout tubes are required to be used, use suitable smaller diameter grout tubes.

- Fix reference buttons (6.12) to the connecting rod ends securing them firmly with Loctite 577.
- Tighten setting rods (Refer Figure 3.2) (6.10, 6.11) to reference buttons. Do not use any Loctite 577 in this case, as the setting rods will have to be removed later on.
- Tighten mounting plate on the setting rods with M8 nuts and washers provided. Take care that the grout pipe/pipes are routed through the central hole of the mounting plate.

13. Connect the flexible grout tubing to grout pump and pump grout till anchor closest to the mouth is fully covered with grout. Grout should never be filled up to the mouth of the borehole.
14. Withdraw flexible grout tubing progressively from the hole as grout is filled in. Clean the grout pipe/pipes for subsequent use by pumping fresh water. Let grout set for at least 24 hours.

**NOTE:** Grout should never be filled up to the mouth of the borehole because some flexibility is required in positioning the connecting rods inside the housing. It also eliminates any possibility of grout flowing into the PVC protective pipe.

Grout should cover the anchor closest to the mouth or be around 1 m from the face of the borehole whichever distance is less.

15. Remove setting space (Refer Figure 2.1) (6.10). Insert C'sk screw M6 x 50 (6.11) over connecting rod extensions and position it properly in the groove on the housing. Tighten reference button (6.12) to the housing with the three Allen head bolt (6.8) provided.
16. Remove setting rods. In case they do not come out easily lock two M8 nuts together on the threaded portion and remove with spanner.
17. Assemble reference plate (Refer Figure 2.1) (6.9) to reference button (6.12) with Allen head bolt (6.8) keeping holes between reference plate and reference button aligned.
18. Put permanent identification marks on the side of housing.
19. Take initial depth reading of the reference buttons (6.12) from the reference plate (6.9) with the depth micrometer (least count 0.01 mm). These will form the reference readings. Difference of these readings from any subsequent readings will give the deformation.

**NOTE:** If installation is correct, depth of reference button from reference plate at time of initial reading will be around 125 mm.

20. Securely tighten cover (6.13) over housing (6). In case there is any chance of damage to the assembly due to construction activity or vandalism, provide additional protection as per requirement.

**NOTE:** Personnel involved in installation and monitoring must have a background of good installation and monitoring practices and knowledge of the fundamentals of geotechnics. They must be professionally trained. Novices may find it difficult to carry on with this work. Intricacies involved are such that even if a single essential but apparently minor requirement is ignored or overlooked, the most reliable of instruments and data obtained from them will be rendered useless.

This method statement does not provide for each and every condition in the field that may affect the performance of the instrument. Also, blindly following the method statement will not guarantee success. Sometimes, depending upon field conditions, the personnel will have to consciously depart from the written text and use their knowledge and common sense to find the solution to a particular problem.

It is recommended that potential users themselves practice all operations laid down in the method statement.